

Selection of a Cognitive Assessment Battery

Robert M. Bilder, PhD

Professor in Residence of Psychiatry & Biobehavioral
Sciences and Psychology,

Jane & Terry Semel Institute for
Neuroscience & Human Behavior

UCLA



Disclosures

- Employer: UCLA
- Consultant, advisor and/or grantee:
 - Abbott
 - Janssen
 - Eli Lilly
 - Lundbeck/Solvay
 - Pfizer
- Royalties/licensing fees received for:
 - CGI-CogS
- Shareholder:
 - Cogtest Inc

Overview

- Battery selection history, principles and targets
- MATRICS Battery – strengths and possible limitations
- Psychometric considerations and bottom-line issues for tradeoffs between feasibility and precision of measurement

Neurocognitive Endpoints: Old and New

- Traditional measures (1890's to 1980's)
 - IQ and “ability” derivatives (Wechsler, Army “beta”)(1908-1950's)
 - Neurological tradition (Halstead-Reitan, Benton)(1890's to 1940's)
 - Experimental psychology and ‘information processing’ (1890's to 1980's)
- “Cognitive neuroscience” methods (1980's – present)
 - Cross-validation streams: functional imaging, genomics/pharmacogenomics, animal models

Neurocognitive Test Roots

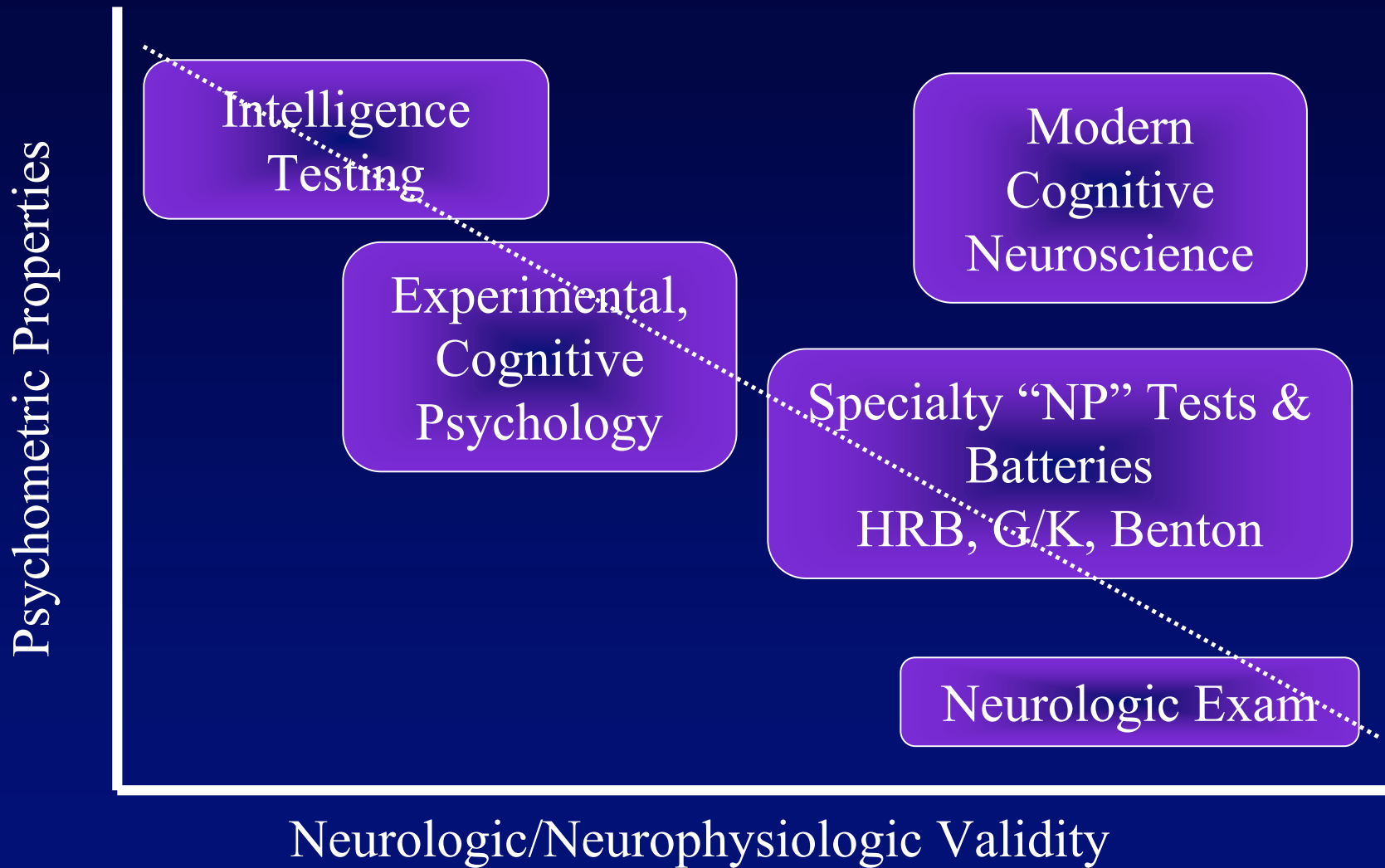

Test selection for neurocognitive trials: Should we “round up the usual suspects”?



- ? What is in PI's filing cabinet
- ? Prior use in successful clinical trials
- ? Validation with respect to other target symptoms or outcomes
- ? Relevant to drug action, based on clinical or pre-clinical evidence
- ? Relevant to pathophysiologic hypotheses
- ? What to do in the “Post-MATRICES Era”

What do you want to measure?

- Neurocognitive function in schizophrenia (global or composite impairment)?
- Specific profile of neurocognitive strengths and weaknesses?
 - Note: Buchanan report of Neuropharmacology committee (MATRICS) suggested clear majority of investigators value specific targets

MATRICS

Test Selection Process

- Before Rand Panel Selection
 - Considered factor analytic studies regarding separable cognitive domains (Nuechterlein et al 2004)
 - Conclusions suggest separable domains can be measured, based on existing literature
 - Does MATRICS battery assess separable domains?

Initial Expert Consensus on Selection Criteria

- High immediate test-retest reliability
- Good coverage of individual cognitive constructs
- Comparable alternative forms
- Clear relationship to functional outcome
- Strong internal consistency of individual scales
- Well-established norms for general population

Does drilling down maintain the initial goal?

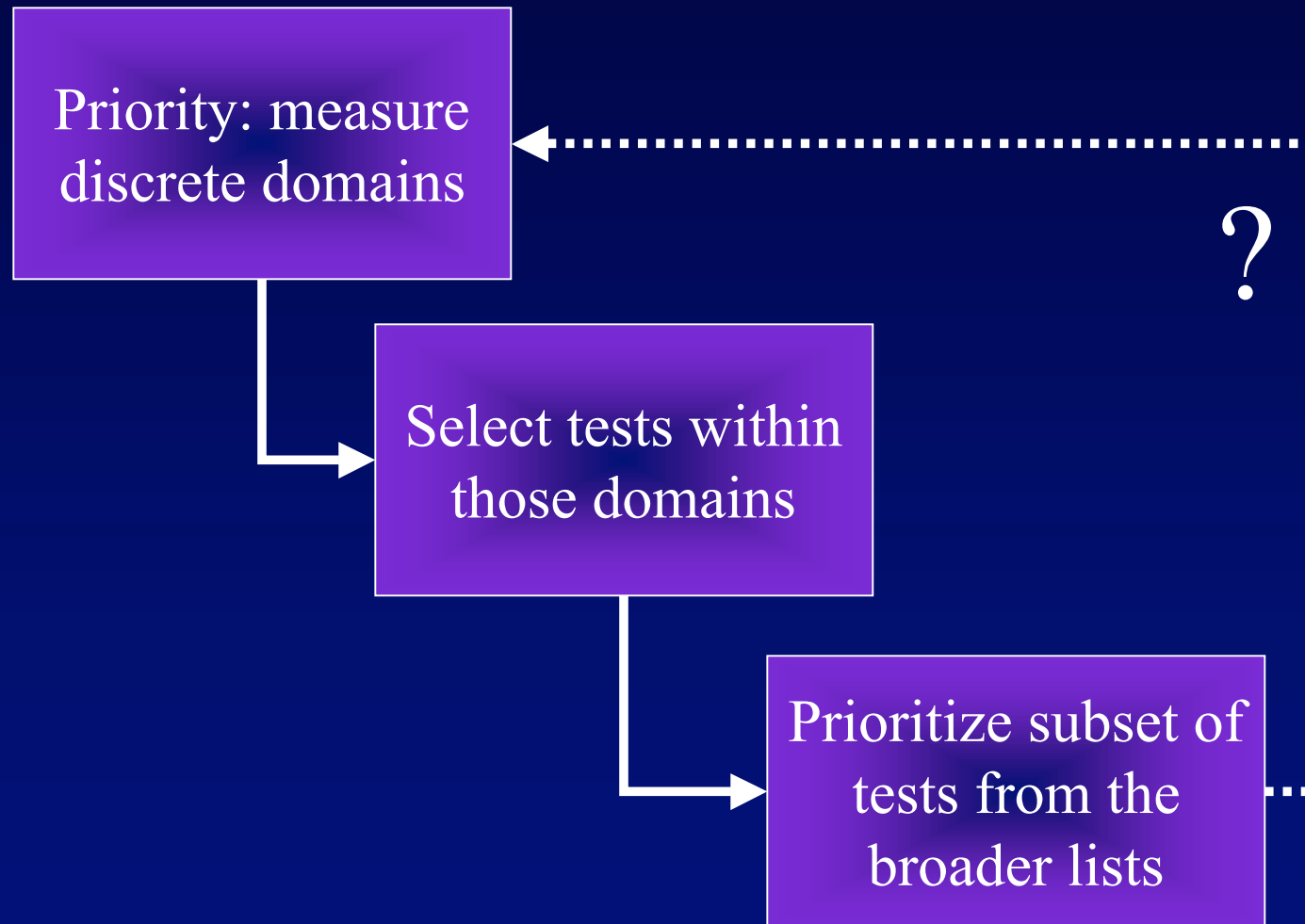

Domain Assessment

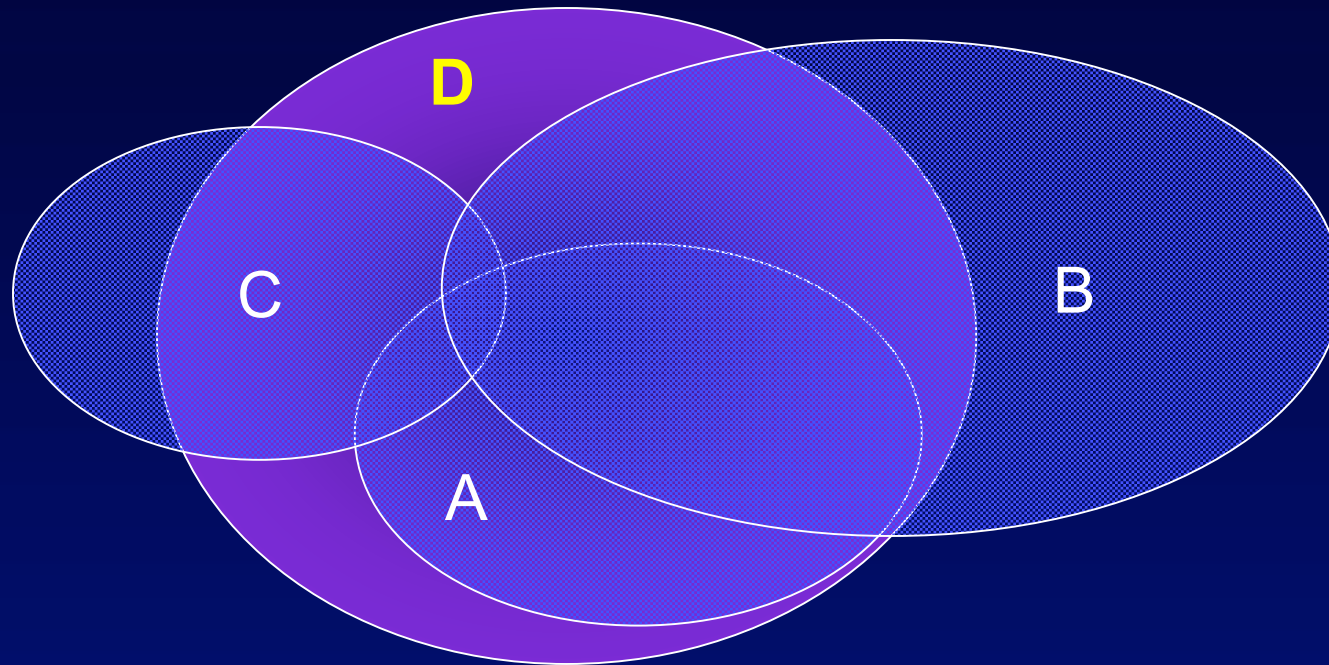

D = domain to be measured

A = test with good specificity to construct

B = test with good sensitivity to construct

C = test with fair specificity, measures important variance in the construct not measured by B and C

MATRICES

Rand Panel Criteria for Test Selection

- a) test-retest reliability
 - b) utility as a repeated measure
 - c) relationship to functional outcome
 - d) potential changeability in response to pharmacological agents
 - e) practicality and tolerability
- Not – sensitivity/specificity to original construct...

What does it take to assess a discrete domain?

- Adequate specification of a “factor” usually relies on **3 independent indicators**
- Beware factor analyses using indicators that share method variance (e.g., immediate and delayed recall trials of same test)
- If a single indicator is used to “tap” a particular construct, then there is:
 - A high probability that this construct will not be adequately measured
 - A high probability that variation due to “error” will affect findings

Mapping Cognition in Schizophrenia

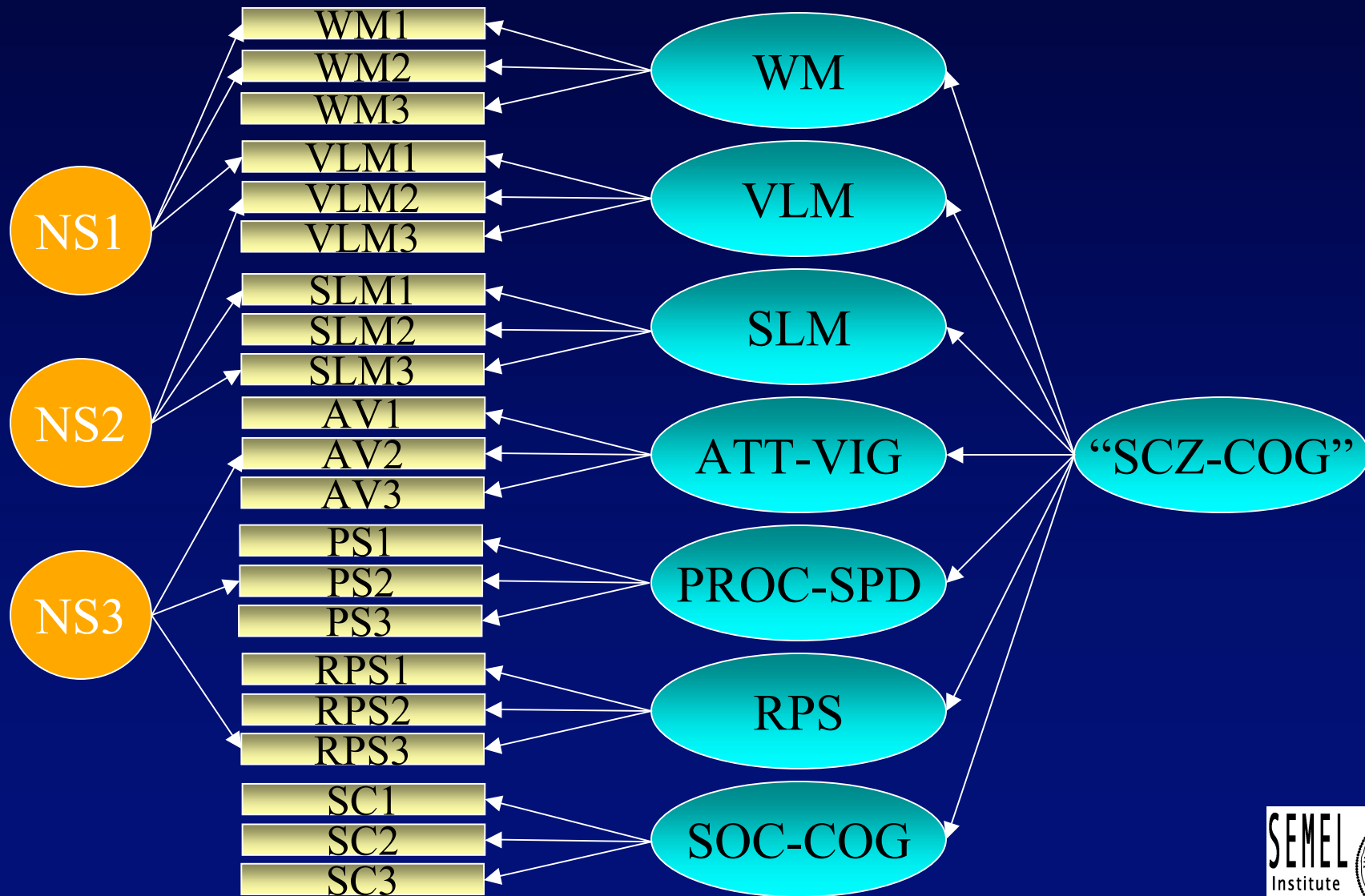

MATRICES – provisional consensus cognitive battery

Domain	Test	Time (min)
Speed of Processing	Category Fluency	2
	Brief Assessment of Cognition in Schizophrenia (BACS) - Symbol-Coding	3
	Trail Making A	2.1
Attention/Vigilance	Continuous Performance Test - Identical Pairs (CPT-IP)	13.4
Working Memory	University of Maryland - Letter-Number Span	5.9
	Wechsler Memory Scale (WMS) - III Spatial Span	5.1
Verbal Learning	Hopkins Verbal Learning Test (HVLT) - Revised	4.1
Visual Learning	Brief Visuospatial Memory Test (BVMT) - Revised	4.7
Reasoning and Problem Solving	Neuropsychological Assessment Battery (NAB) - Mazes	11.2
Social Cognition	Mayer-Salovey-Caruso Emotional Intelligence Test (MSCEIT) - Managing Emotions	12
Total Time		63.5

MATRICES Construct Definitions

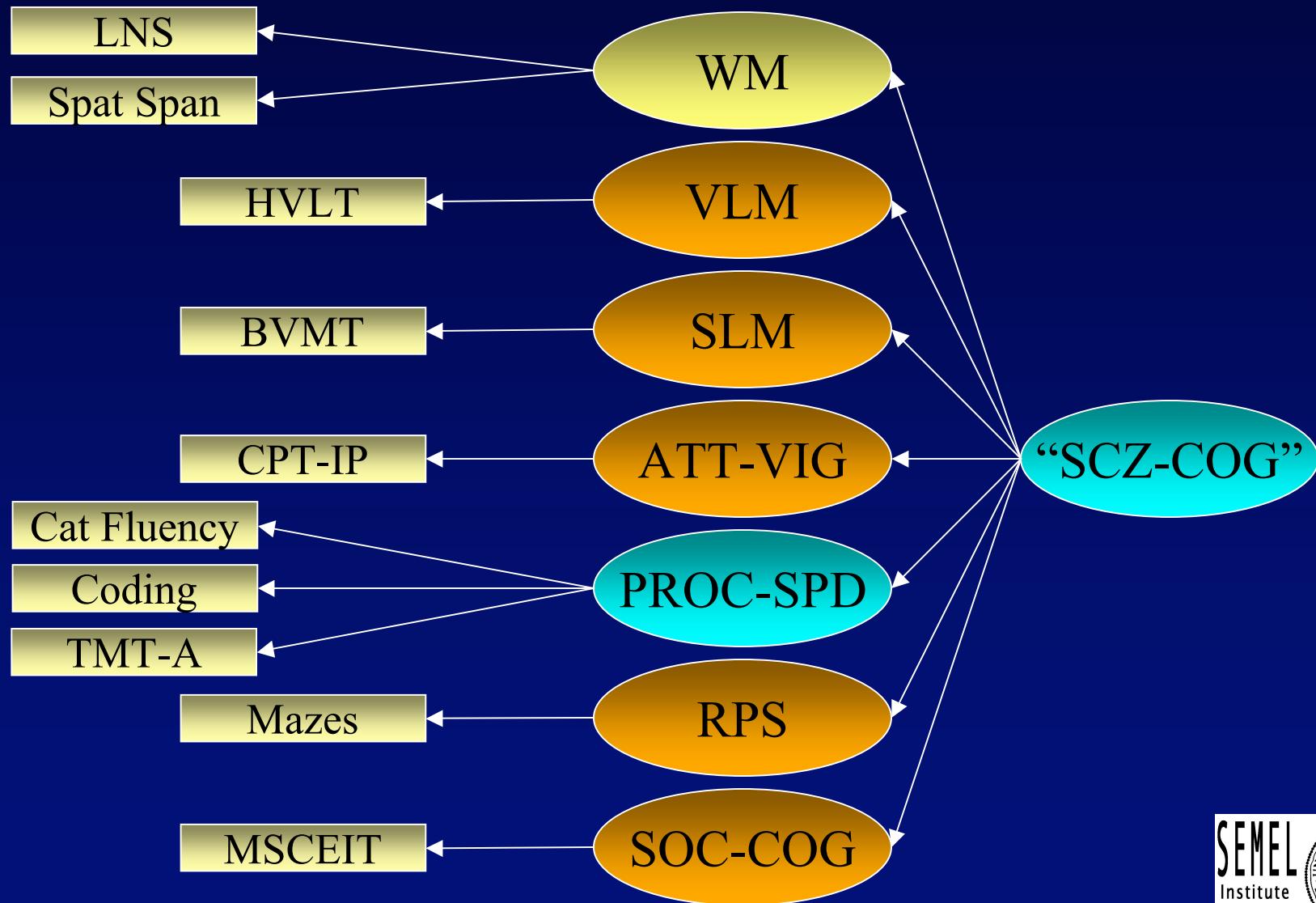

Mapping Cognition in Schizophrenia: General Cognitive Endpoint

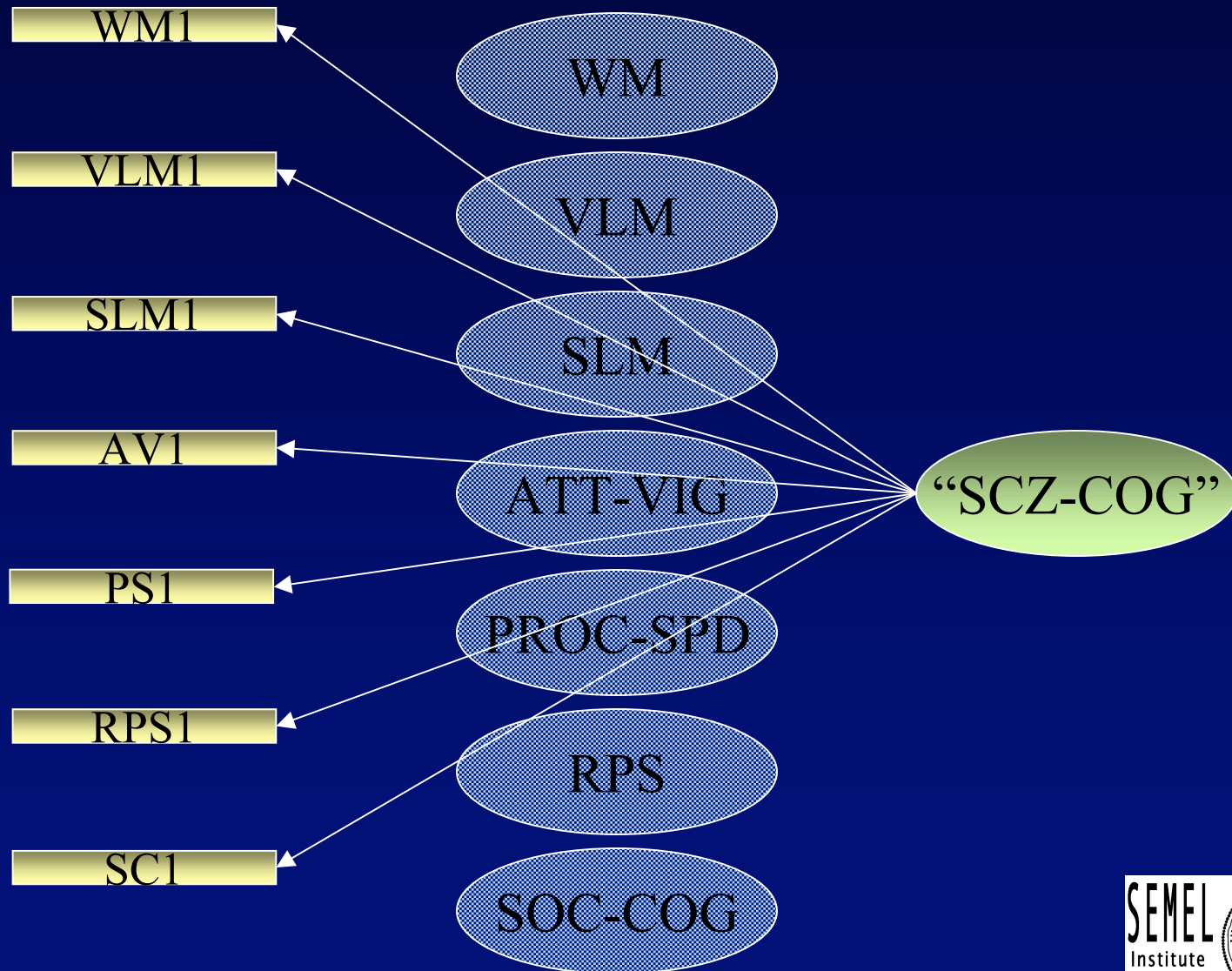

Mapping Cognition in Schizophrenia: Specific Hypothesis Endpoints

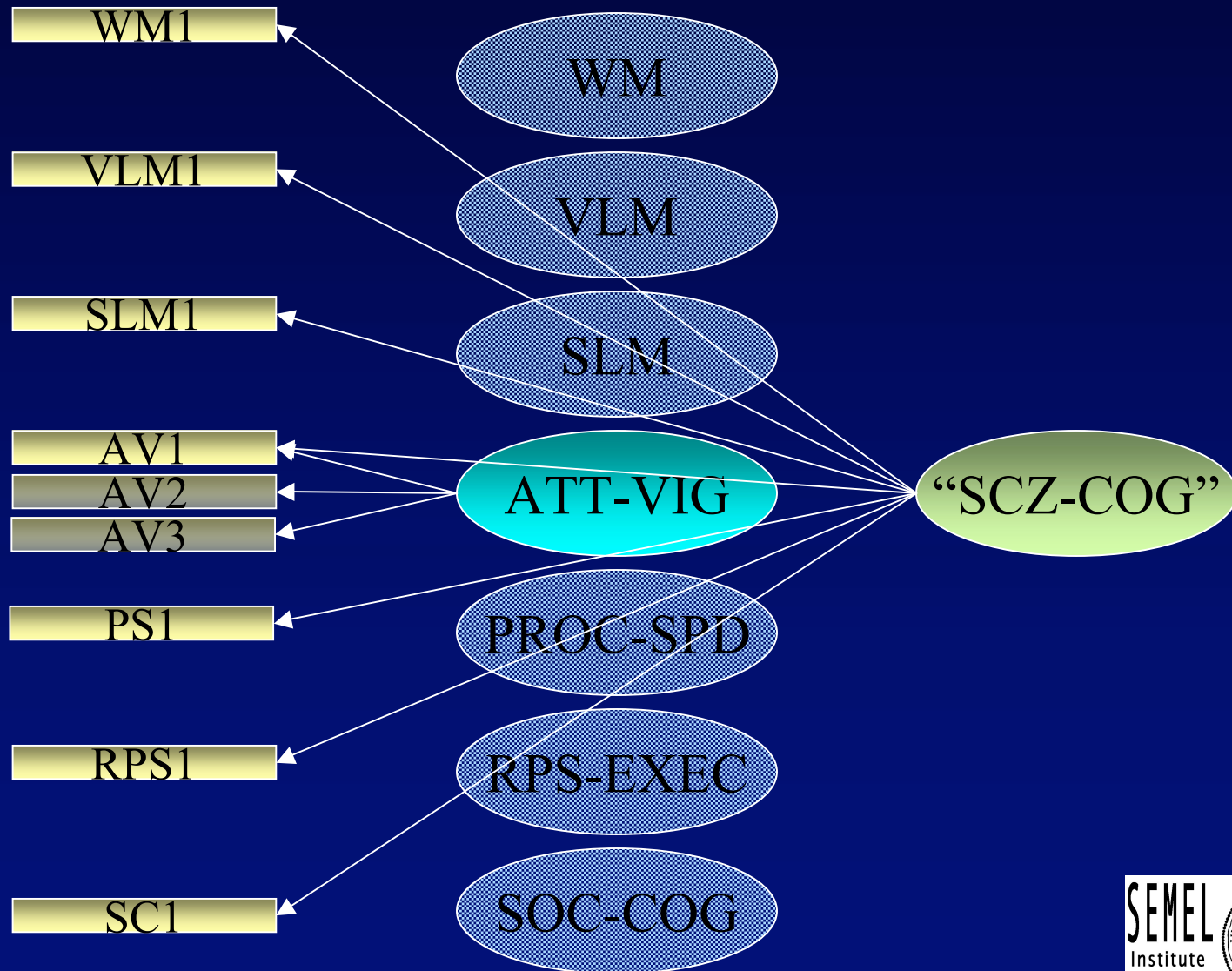

Example: CFA of CATIE Data

- Analysis of 9 or 10 tests, which generate 9 to 20 variables, with more than 1000 patients
- If you aggregate scores to examine (9) *independent* indicators, there is one (big) factor
- If you use elemental scores (multiple per test which share method variance) you can generate an acceptable 6 factor solution using CFA (but is this meaningful?)

Conclusions (1)

- MATRICS battery does an excellent job of representing the global domain of functions consensually considered impaired in schizophrenia
- MATRICS battery likely measures well processing speed, maybe working memory
- It remains unclear how well other domains are assessed (insights from PASS study?)
- If you want to assess these domains, you need additional measures

Conclusions (2)

- If your goal is to measure global cognitive functioning, it is likely that a subset of MATRICS battery, or compilation of similar tests will yield similar precision of measurement
- Useful validation of this concept could come from analysis of MATRICS-PASS data, or stand-alone studies